

## DESIGN FEATURES

Cast stainless steel Body, Gate, Packing gland and Yoke  
Bonnetless, Rising stem, Non-rising handwheel, Outside screw- and-yoke

- Available in sizes from 2" to 24" diameter
- Meet TAPPI standard TIS 405-8 and MSS SP-81 for stainless steel bonnetless, flanged, wafer knife gate valves.
- Flanges are drilled and tapped to ANSI B16.5, BS 4504, JIS or DIN.
- 150 PSI maximum working pressure and 150°F (65 °C) maximum working temperature. Special design should be considered for applications outside of these conditions.
- Non-clogging full port design for smooth flow
- Easy conversion from handwheel to cylinder, bevel gear or electric motor operator with cast yoke.
- Precision machined gate for superior seating capability
- Stainless steel stem for corrosion resistance
- Resilient or PTFE replicable seat available
- O-ring resilient seat available
- Factory installed V-port seat insert available

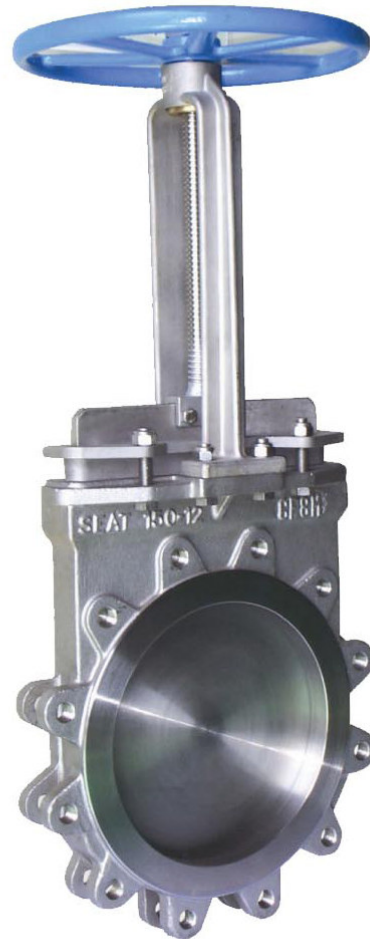

# VALVE DIMENSIONS AND OPTIONS

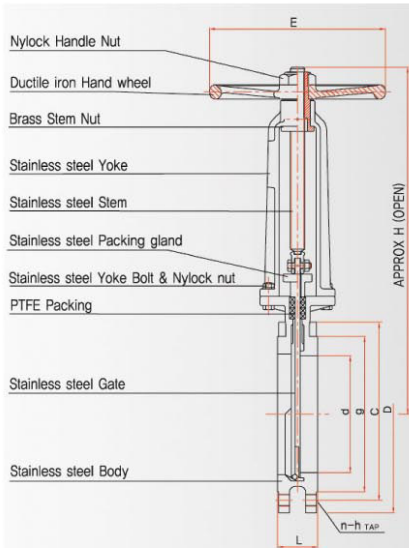

## Options/Modifications

SAMJIN JMC offers many options. Knife gate valves can be modified to suit a customer specific requirements. These include, but are not limited to:

- Packing options for pH and temperature requirements
- Stem extension and non-rising stem adapters in carbon and stainless steel
- Stem covers to prevent ingress of foreign matters
- Mechanical or proximity limit switches for position indication
- V-port seat insert for metering and throttling service
- Actuation including chain wheels, gear operators, pneumatic & hydraulic cylinders, electric actuators, etc.

## Design Standards

Face to Face Dimensions	MSS SP-81 / TIS 405-8
End Flanges Dimensions	ANSI B16.5
Test	MSS SP-81 / TIS 405-8
Seat/Shell Test	MSS SP-81 / API 598
Pressure-Temperature rating	ASME B16.34

[unit : inch]

Size	L	d	FLANGE						E	H	H'
			D	C	g	t(min.)	n-h TAP				
2	1.88	2.0	6.00	4.75	3.62	0.50	4	5/8-11	8.00	12.60	14.60
3	2.00	3.0	7.50	6.00	5.00	0.50	4	5/8-11	8.00	14.57	16.57
4	2.00	4.0	9.00	7.50	6.19	0.50	8	5/8-11	8.00	16.54	18.54
6	2.25	6.0	11.00	9.50	8.50	0.63	8	3/4-10	12.00	21.00	23.00
8	2.75	8.0	13.50	11.75	10.62	0.63	8	3/4-10	12.00	23.74	25.74
10	2.75	10.0	16.00	14.25	12.75	0.75	12	7/8-9	16.00	28.35	30.35
12	3.00	12.0	19.00	17.00	15.00	0.75	12	7/8-9	16.00	32.24	34.24
14	3.00	13.25	21.00	18.75	16.25	0.81	12	1.00-8	16.00	36.42	38.42
16	3.50	15.25	23.50	21.25	18.50	0.88	16	1.00-8	18.00	40.16	42.16
18	3.50	17.25	25.00	22.75	21.00	0.94	16	1¼-7	18.00	45.67	47.67
20	4.50	19.25	27.50	25.00	23.00	1.00	20	1¼-7	20.00	53.15	55.15
24	4.50	23.25	32.00	29.50	27.25	1.00	20	1¼-7	20.00	61.22	63.22

[unit : mm]

Size	L	d	FLANGE						E	H	H'
			D	C	g	t(min.)	n-h TAP				
50	47.8	51	152	121	92	12.7	4	5/8-11	200	320	350
80	50.8	76	191	152	127	12.7	4	5/8-11	200	370	420
100	50.8	102	229	191	157	12.7	8	5/8-11	200	420	470
150	57.2	152	279	241	216	16.0	8	3/4-10	300	530	580
200	69.8	203	343	298	270	16.0	8	3/4-10	300	600	650
250	69.8	254	406	362	324	19.1	12	7/8-9	400	720	770
300	76.2	305	483	432	381	19.1	12	7/8-9	400	820	870
350	76.2	337	533	476	413	20.6	12	1.00-8	400	925	975
400	88.9	387	597	540	470	22.4	16	1.00-8	450	1020	1070
450	88.9	438	635	578	533	23.9	16	1¼-7	450	1160	1210
500	114.0	489	698	635	584	25.4	20	1¼-7	500	1350	1400
600	114.0	591	813	749	692	25.4	20	1¼-7	500	1555	1605

Note : H' for rubber seated type

# SEAT DESIGN AND STANDARD MATERIAL SPECIFICATION

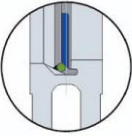
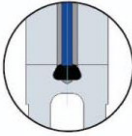
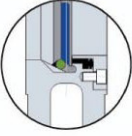
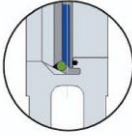
	<p><b>Metal to Metal Type (MMT)</b></p> <ul style="list-style-type: none"> <li>• Integral stainless seat</li> <li>• Uni-directional flow</li> <li>• Fluid pressure assists sealing capacity</li> <li>• Full flow port area</li> </ul>		<p><b>Metal to Rubber Type (MRT)</b></p> <ul style="list-style-type: none"> <li>• Bi-directional bubble-tight shut off</li> <li>• Positively retained seat</li> <li>• No grooves or pockets to collect product</li> </ul>
	<p><b>Metal to PTFE Type (MPT)</b></p> <ul style="list-style-type: none"> <li>• O-ring energized PTFE seat ring</li> <li>• Uni-directional flow</li> <li>• Easily replaceable seat</li> <li>• Other materials available such as Polyethylene or Nylon</li> </ul>		<p><b>Metal to O-ring Type (MOT)</b></p> <ul style="list-style-type: none"> <li>• Resilient O-ring in omega-shaped groove</li> <li>• Uni-directional flow</li> <li>• Bubble-tight shut off</li> <li>• Lower torque</li> </ul>

Note : Uni-directional valves must be installed with seat downstream.

## Standard Material Specifications

NO	MATERIALS OF CONSTRUCTION	MODEL	
	Part Name	MK & RK SERIES	MK & RK SERIES
1	Body	ASTM A351 Gr. CF8(304) St/Stl	CF8M (316) St/Stl
2	Disc/Gate	ASTM A240 TP 304 St/Stl	316 St/Stl
3	Packing	PTFE Impregnated Syntax Yarn (Non-asbestos)	
4	Packing Gland	ASTM A351 Gr. CF8 (304) St/Stl	CF8M (316) St/Stl
5	Gland Bolt and Nut	ASTM A193 Gr. B8 / ASTM A194 Gr. 8 (Nyloc)	
6	Stem	ASTM A479 TP 304 St/Stl	
7	Disc Bolt and Nut	ASTM A193 Gr. B8 / ASTM A194 Gr. 8 (Nyloc)	
8	Stem Nut	Brass or Bronze	
9	Yoke	ASTM A351 Gr. CF8 (304) St/Stl	
10	Yoke Bolt and Nut	ASTM A193 Gr. B8 / ASTM A194 Gr. 8 (Nyloc)	
11	Thrust Bearing Washer	Brass (Sizes 300mm and Smaller)	
12	Hand Wheel	Cast Ductile Iron	
13	Wheel Nut	AISI 1020 with Cr. PLATE (Nyloc)	
14	Set Screw	N/A	
15	Grease Nipple	Assembly	
16	Name Plate	ASTM A240 TP 304 St/Stl	
17	Rivet	Aluminium	
18	Body Seat* (MRT)	Buna - N	
19	Stopper and Nut (MRT)	ASTM A479 Ty. 304 / ASTM A194 Gr. 8 (Nyloc)	
20	Body Seat Ring (MPT)	Reinforced PTFE	
21	V-Port Body Seat Ring (MVT)	ASTM A276 TP 304 St/Stl	ASTM A276 TP 316 St/Stl
22	O-Ring* (MOT)	Hycar Rubber	
23	Seat Retainer (MPT)	ASTM A351 Gr. CF8 (304) St/Stl or EQ.	CF8M (316) St/Stl or EQ.
24	Wrench Bolt (MPT)	ASTM A193 Gr. B8	
25	Bearing Housing	ASTM A351 Gr. CF8 (304) St/Stl CF8M (316) St/Stl	
26	Housing Bolt and Nut	ASTM A193 Gr. B8 / ASTM A194 Gr. 8 (Nyloc) B8M	
27	Thrust Ball Bearing	Assembly	
28	Sleeve Gland	ASTM A351 Gr. CF8 (304) St/Stl	

\* Other materials are available : FPM(Viton), EPDM, CR(Neoprene), NBR, etc.

# OPERATORS AND SEAT MATERIAL PROPERTIES

## Valve Operators

	<p><b>Handwheel</b></p> <p>Valves are equipped with handwheels as basic for manual operation.</p>		<p><b>Bevel Gear</b></p> <p>Bevel gear operation is designed to minimize the effort to operate larger sized manual-operated valves which is out of reach.</p>		<p><b>Cylinder</b></p> <p>valve can be available with air or hydraulic cylinder operator if remote operation is required</p>
	<p><b>Electric &amp; Air Motor</b></p> <p>Valves can be furnished with electric, pneumatic or hydraulic motor drives for remote, automatic or frequent operation.</p>		<p><b>Lever</b></p> <p>Where rapid valve operation is required, quick opening lever operators can be provided instead of handwheel.</p>		<p><b>Chain Wheel</b></p> <p>Chain wheel is an efficient means of operating the valves overhead and out-of-reach</p>

## Guide to Chemical Resistance for Resilient Seats

COMMON NAME	ASTM CODE	MAX. TEMP.	ABRA-SION	AGING	SUN LIGHT RESIS-TANCE	WATER RESIS-TANCE	OIL RESIS-TANCE	SOLVENT	STRONG ACID	WEAK ACID	STRONG ALKALI	WEAK ALKALI
BUNA-N	NBR	200°F	⊙	⊙	○	⊙	⊙	△	×	○	○	⊙
NEOPRENE	CR	200°F	⊙	⊙	⊙	⊙	⊙	×	×	○	○	⊙
NATURAL RUBBER	NR	150°F	⊙	○	○	⊙	×	×	×	○	○	⊙
EPT.	EPDM(EPT)	250°F	○	⊙	⊙	⊙	×	×	○	⊙	⊙	⊙
SILICON	Si	300°F	○	⊙	⊙	○	× ~ ○	△	×	○	○	⊙
VITON	FPM	300°F	○	⊙	⊙	⊙	⊙	○	○	⊙	⊙	⊙
PTFE	D-1457	500°F	⊙	⊙	⊙	⊙	⊙	⊙	⊙	⊙	⊙	⊙

Note: ⊙ excellent, ○ good, △ fair, × poor